

Matrox

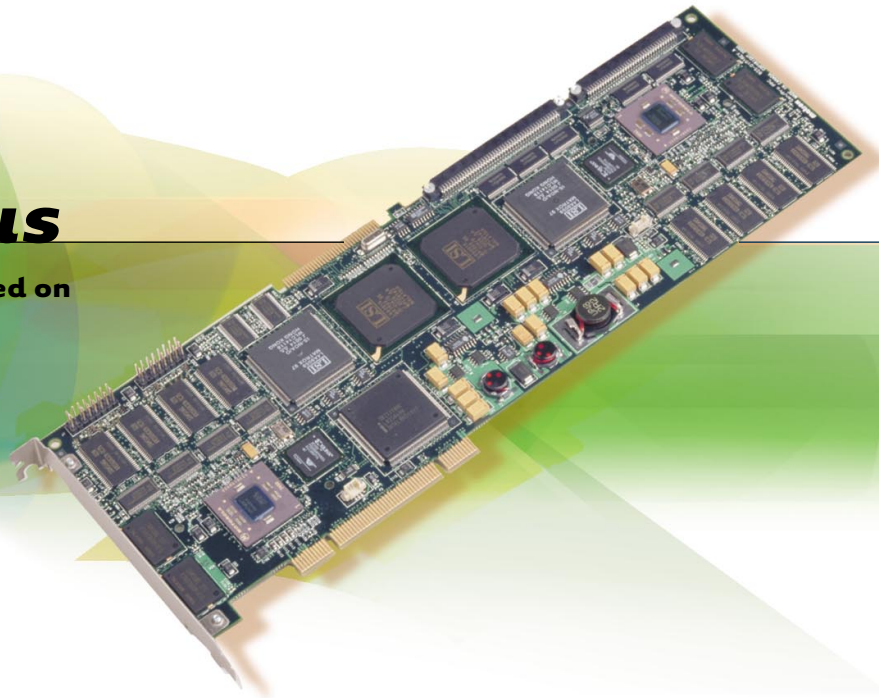

GenesisPlus

**Vision processor board based on
Motorola's PowerPC™ with
AltiVec™ technology.**



More Power for a Proven Vision Processor

The latest addition to the award-winning Matrox Genesis family of vision processor boards is the Matrox GenesisPlus featuring a Motorola® G4¹ PowerPC processor. Providing more computational power and memory bandwidth, Matrox GenesisPlus is well suited for the most demanding imaging applications, including semiconductor wafer inspection, continuous web inspection and 'live' digital x-ray. It easily integrates into an existing Matrox Genesis image processing system for dedicated real-time image capture, processing and display, or it can be used as a powerful stand-alone processing board.

Best-of-breed Motorola G4 PowerPC microprocessor

The central component of this new Matrox Genesis processing board is the G4. It combines the best features of a general purpose CPU and a DSP providing top performance at a given clock rate. The G4 is also backed by Motorola's solid migration path for increased performance, all the while maintaining code compatibility.

The G4 incorporates a powerful 32-bit superscalar RISC and AltiVec technology's 128-bit vector execution unit. Coupled to the G4 is a 2MB external L2 cache to help sustain maximum processor performance. A 64-bit MPX bus offers extremely efficient access to main memory providing a sustained bandwidth close to theoretical peak performance.

Key features

- long PCI form factor
- one or two processing nodes
- processing node consisting of:
 - G4 processor
 - Matrox Neighborhood Operations Accelerator (NOA) coprocessor
 - Matrox's Video Interface ASIC (VIA) processor bridge
 - 128 or 256 MB SDRAM memory
- VMChannel™ and Grab Port secondary bus interface
- available software is sold separately and includes Matrox Imaging Library (MIL)/ActiveMIL, Matrox Genesis Native Library (GNL) and Matrox GNL Developer's Toolkit
- supports Microsoft® Windows NT® 4.0, Windows® 2000, Windows® XP and QNX® (GNL only)

Matrox GenesisPlus

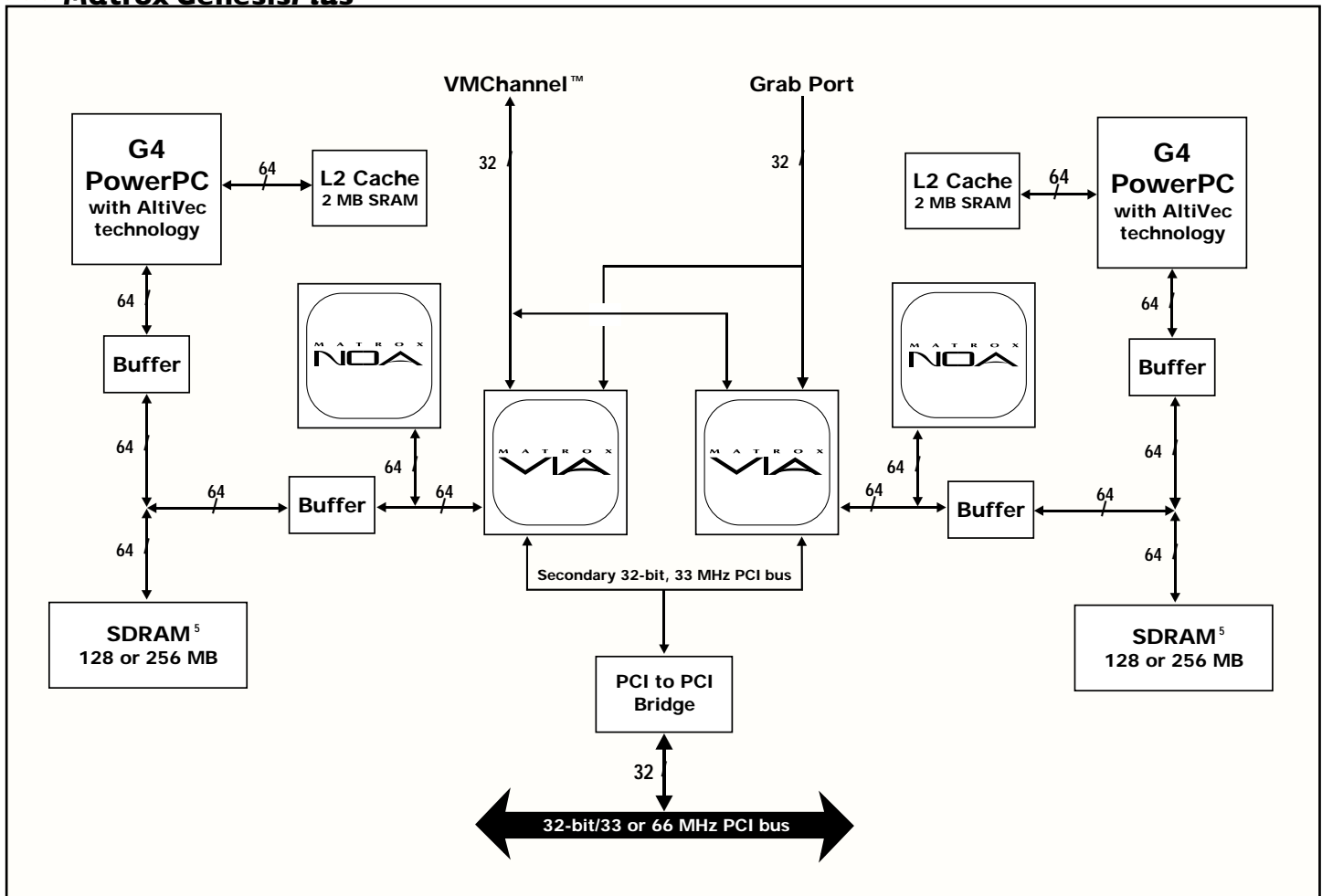

Motorola AltiVec technology

Expanding the performance capabilities of the PowerPC processor, AltiVec technology is specifically designed to meet the heavy computational requirements of applications such as video and image processing. This technology consists of a high-performance parallel processing engine for vector data. It uses the SIMD (single instruction, multiple data) model to process, in parallel, up to 16 pixels per cycle. It delivers a peak processing power of 8000 MMACs² per second or 4000 MFLOPs³ when running at 500 MHz. Moreover, AltiVec technology operates concurrently with other execution units within the G4.



Matrox Neighborhood Operations Accelerator (NOA)

Working in conjunction with the G4 is the Matrox-designed NOA coprocessor. The Matrox NOA is used for accelerating neighborhood operations including convolutions, binary and gray-scale morphology. Image compression/decompression is supported by the integrated lossless JPEG codec. The Matrox NOA consists of an array of 32 MACs (multipliers/accumulators) running at 50 MHz, which can perform up to 6.4 BOPs⁴.



Scalable architecture

Matrox GenesisPlus offers the same scalable architecture pioneered by the original Matrox Genesis family. Adding processing nodes to a system not only increases computational power, but also increases memory bandwidth. Up to 12 G4/NOA processing nodes can be connected within a system. The dedicated VMChannel™ and Grab Port links provided by Matrox-designed Video Interface ASIC (VIA) relieves the host PCI bus of image processing data traffic. In addition, the Matrox VIA enables the G4 and NOA to be dedicated to processing by offloading data management tasks.

Software environment

The software environment for the Matrox GenesisPlus consists of the familiar Matrox Imaging Library (MIL) or Matrox Genesis Native Library (GNL). Both MIL or GNL are used from within an application running on the host to access over 300 imaging operations running on the G4 and Matrox NOA. Available operations include image processing, blob analysis and pattern matching. These operations are fully optimized to exploit the power of the G4 with AltiVec technology and the Matrox NOA.

Dedicated Links

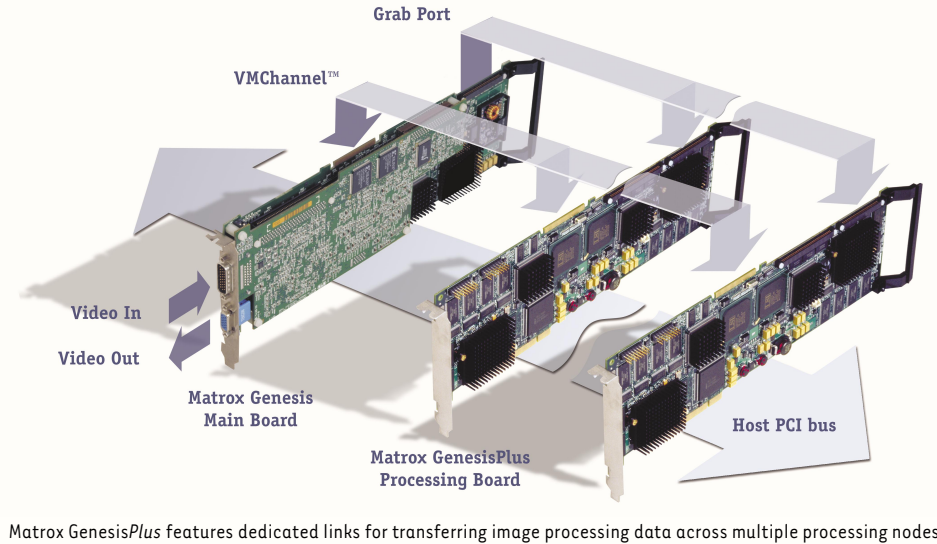

Software environment (cont.)

Supported host environments are Microsoft® Windows NT® 4.0, Windows® 2000, Windows® XP and QNX® (GNL only). Custom code development for the PowerPC processor is supported using the GNL Developer's Toolkit (DTK) and is done entirely in C/C++ including optimizations for AltiVec technology. No exotic assembly code is required. Moreover, custom code developed today will be compatible with future generations of the Motorola PowerPC.

Hardware Specifications

- one or two processing nodes with G4, Matrox Neighborhood Operations Accelerator (NOA), Matrox Video Interface ASIC (VIA) and main memory
- G4 (MPC7410)
 - 32-bit superscalar RISC
 - 500 MHz core speed
 - 2 MB external L2 cache
 - 64-bit, 125 MHz MPX bus interface to main memory
- Matrox Neighborhood Operations Accelerator (NOA)
 - array of 32 MACs (multipliers/accumulators)
 - 50 MHz core speed
- 128 or 256 MB SDRAM main memory⁵ per node
- 32-bit, 33/66MHz PCI interface
- 32-bit, 33MHz VMChannel™ interface
- 32-bit, 50MHz Grab Port interface
- universal PCI card edge connector

Dimensions and environmental information

- 31.4 L x 10.7 H x 1.73 W cm (12.4" x 4.2" x 0.68") from bottom edge of goldfinger to top edge of board
- 34.1 L x 10.7 H x 1.73 W cm (13.4" x 4.2" x 0.68") including retainer
- power consumption: 6.7A @ 5V or 33.5W, 0.1A @ 12V or 1.2W, 34.7W total (GPG4N/500/256/2)⁶
- operating temperature: 0° C to 55° C (32° F to 131° F)
- ventilation requirements: 100 LFM (linear feet per minute) over board(s)
- relative humidity: up to 95% (non-condensing)
- FCC class A
- CE class A

Software Environment

- Host driver for Microsoft® Windows NT® 4.0, Windows® 2000, Windows® XP and QNX®
- Windows® development done using DLL interface (MIL and GNL) with Microsoft® Visual C++® or ActiveX interface (ActiveMIL) with Microsoft® Visual Basic® or C++®
- QNX® (GNL only) development done using LIB interface with QNX® IDE
- Custom code development for G4 PowerPC processor done using GNL DTK with Metrowerks® CodeWarrior® for PowerPC Embedded Systems

Ordering Information

Part number	Description
Hardware	
GPG4N/500/128/1	Single-node PCI processor board with MPC7410 @ 500 MHz, NOA, and 128 MB SDRAM.
GPG4N/500/256/1	Single-node PCI processor board with MPC7410 @ 500 MHz, NOA, and 256 MB SDRAM.
GPG4N/500/128/2	Dual-node PCI processor board with MPC7410 @ 500 MHz, NOA, and 128 MB SDRAM per node.
GPG4N/500/256/2	Dual-node PCI processor board with MPC7410 @ 500 MHz, NOA, and 256 MB SDRAM per node.

See Matrox Genesis, Matrox Genesis Developer's Toolkit and Matrox Imaging Library brochures for information regarding companion boards, peripherals and software tools.

Notes:

1. G4 refers to the Motorola MPC7410 PowerPC microprocessor.
2. 8 billion 8-bit multiply accumulates per second.
3. 4 billion 32-bit floating point operations per second.
4. 6.4 billion operations per second.
5. Only 64 MB visible to VIA and NOA.
6. 6.9A @ 5V or 34.5W, 0.1A @ 12V or 1.2W, 35.7W total for GPG4N/400/256/2 with MPC7400 and 6A @ 5V or 30W, 0.1A @ 12V or 1.2W, 31.2W total for GPG4N/400/256/2 with MPC7410.

Motorola is a registered trademark, and Digital DNA and AltiVec technology are trademarks of Motorola, Inc. PowerPC is a trademark of International Business Machines Corporation, used under license therefrom.

matrox

For more information, please call: 1-800-804-6243 (toll free in North America)
or (514) 822-6020 or e-mail: imaging.info@matrox.com or <http://www.matrox.com/imaging>

Corporate headquarters:

Canada and U.S.A.
Matrox Electronic Systems Ltd.
1055 St. Regis Blvd.
Dorval, Quebec H9P 2T4
Canada
Tel: (514) 685-2630
Fax: (514) 822-6273

Offices:

Europe, Middle East & Africa
Matrox VITE Limited
Sefton Park
Stoke Pages
Buckinghamshire
SL2 4JS
UK
Tel: 01753 665511
Fax: 01753 665599

France
Matrox France SARL
2, rue de la Couture
Silic 225
94528 Rungis Cedex
Tel: (0) 1 45-60-62-00
Fax: (0) 1 45-60-62-05

Germany
Matrox Electronic Systems GmbH
Inselkammerstr. 8
D-82008 Unterhaching
Tel: 089/62170-0
Fax: 089/614 9743

All trademarks by their respective owners are hereby acknowledged. Matrox Electronic Systems, Ltd. reserves the right to make changes in specifications at any time and without notice. The information furnished by Matrox Electronic Systems, Ltd. is believed to be accurate and reliable. However, no responsibility license is granted under any patents or patent rights of Matrox Electronic Systems, Ltd. Windows and Microsoft are trademarks of Microsoft Corporation. MMX and the MMX logo are registered trademarks of Intel Corporation. Printed in Canada, 06-05-2002. **51E-5189-B**