

**Matrox**

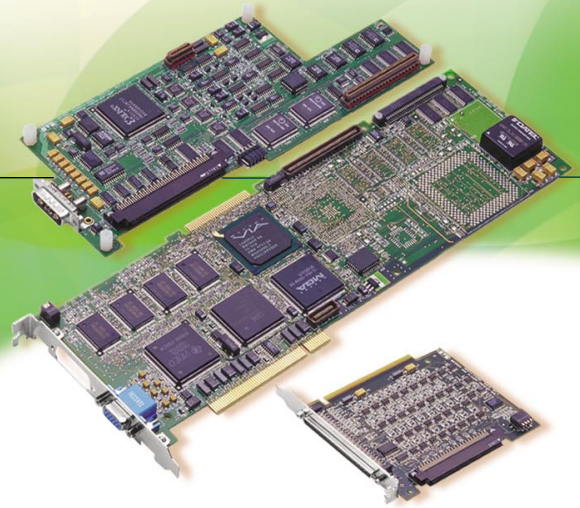

# Genesis-LC

**High-throughput PCI frame grabber for flexible color/monochrome acquisition, with simultaneous capture to integrated display and transfer to host.**



## Matrox Genesis-LC

Matrox Genesis-LC provides exceptional flexibility for interfacing to the complete range of cameras and other video devices used in industrial, scientific and medical applications.

### Software

Software support for Matrox Genesis-LC includes Matrox Imaging Library (MIL), a comprehensive high-level library that includes ActiveMIL, a collection of ActiveX controls (OCXs) for managing image capture, processing analysis, display and archiving.

### High-throughput I/O and real-time image reconstruction

Matrox Genesis-LC was designed for high-throughput I/O. The VIA (Video Interface ASIC), custom designed by Matrox, is an intelligent controller that writes image data directly to on-board memory and, in parallel, transfers it in real-time over the PCI bus to system RAM. This results in simultaneous display and processing of images. The VIA is also a powerful image formatting engine that can reconstruct image data from multi-channel video sources as it is written to system and display memory. Input cropping, pixel tagging, zooming and sub-sampling can also be performed in real-time.

### Integrated display

With an on-board display section, Matrox Genesis-LC does not require the use of a VGA card and an additional PCI slot. To achieve live image viewing, other frame grabbers create unnecessary load on PCI, since two data streams must be transferred over the bus. Matrox Genesis-LC supports concurrent processing and live display of even high resolution color images without consuming PCI bandwidth. As well, the display section has a split frame buffer architecture allowing non-destructive overlay of text and graphics.

## Key features

- long PCI form factor
- captures from standard/non-standard, color/monochrome, analog/digital, frame/line scan sources
- digitizes at up to 140 MHz
- 32-bit wide RS-422 or LVDS digital interface
- 32-bit/33 MHz PCI bus-master
- simultaneous capture to system and onboard VGA memory
- extensive onboard buffering (up to 6 MB) for reliable capture
- true-color display with pseudo-color non-destructive overlay
- display at up to 1600 x 1200
- VMChannel™ secondary bus interface
- available software is sold separately and includes Matrox Imaging Library (MIL)/ActiveMIL, MIL-Lite/ActiveMIL-Lite and Matrox Inspector
- support for Microsoft® Windows® NT 4.0, Windows® 2000, Windows® XP and QNX®<sup>1</sup>

## Acquisition

### Key features

- analog acquisition at up to 140 MHz
- digital acquisition up to 32-bit wide
- RS-422 and LVDS digital interface at up to 25 MHz and 40 MHz respectively
- frame scan/line scan video input up to 64K pixels per line and 64K lines
- grabs color or monochrome video
- simultaneous capture of up to 4 synchronized video streams
- programmable synchronization and control

### Interfaces to virtually any camera or input device

- high-resolution cameras (color or monochrome)
- line scan cameras including TDI (color or monochrome)
- medical scanners (ultrasound, CT, NM, MRI, X ray, etc.)
- slow-scan devices (e.g., SEM)
- frame reset cameras
- single or multi-tap cameras (time-multiplexed or parallel streams)
- double-speed, progressive-scan cameras
- custom designed input devices
- standard monochrome (RS-170/CCIR)
- standard component RGB cameras
- as well as future video devices such as faster or higher resolution cameras

### Analog video (monochrome and RGB)

- three software-selectable modes:
  - 4 channel/8-bit mode at up to 35 MHz
  - 2 channel/8-bit mode at up to 70 MHz
  - 1 channel/8-bit mode at up to 140 MHz
- grabs standard component RGB or non-standard component RGB color video signals in 4 channel/8-bit mode
- each A/D converter is software programmable for coarse and fine adjustment of level and reference voltages as well as clamping
- low pass filter with cut-off frequencies of 10 MHz (can be bypassed)
- PLL circuitry accurately locks to any video source for reliable image acquisition
- onboard PLL generates a variable scan clock with a programmable frequency from 5-35 MHz and provides phase adjustments: 0°, 90°, 180° and 270°

## Digital video data

- acquires 32-bit digital video data in one of several configurations:
  - four 8-bit channels
  - two 16-bit channels
  - one 32-bit channel
- TTL data acquisition provided onboard
- optional companion board required for RS-422/LVDS format

## Input LUTs

- configurable look-up tables (four 256 x 8-bit, two 8k x 16-bit)

## Synchronization and control

- hsync, vsync, composite sync, pixel clock input or output (TTL/RS-422/LVDS)
- external trigger input (TTL/RS-422/LVDS)
- two exposure (timer) outputs (TTL/RS-422/LVDS)
- auxiliary I/Os (TTL/RS-422/LVDS): two in/two out

## Matrox VIA: acquisition functions

- grab port handles up to 32-bit wide data in either parallel or multiplexed format
- up to 4 synchronized channels can each be assigned a unique destination address and pixel tag
- converts grabbed data into a memory format: 8, 16, 24 and 32-bit pixels
- supports image alignment with one-pixel accuracy
- region-of-interest (ROI) acquisition (input cropping)
- non-rectangular ROI through the use of tagging (for grabbing or transferring to display)
- independent horizontal and vertical zoom by 2 and 4 (pixel replication)
- independent horizontal and vertical sub-sampling ("pixel dropping") on output by integer factors between 2 and 16
- reconstructs non-consecutive pixel data writing to memory in real-time (e.g., from time-multiplexed or multitap cameras, etc.)
- generates start-of-grab, end-of-grab, and grab line interrupts towards the host

## Transfers

### Transfer rate

- sustains transfer rates up to 130 MB/sec between the acquisition section and the host PCI system

### PCI bus master

- acts as a PCI bus master allowing transfers without requiring continuous host intervention

## Integrated Display

### Key features

- supports high-resolution monochrome or color display
- Portrait mode:
  - 1200 x 1600 x 8-bit or 24-bit image display
  - 1200 x 1600 x 8-bit pseudo-color overlay display
- Landscape mode:
  - up to 1600 x 1200 x 8-bit or 24-bit image display
  - up to 1600 x 1200 x 8-bit pseudo-color overlay display
- Matrox MGA 2064W high-performance graphics controller

### Dual frame buffer architecture

- up to 6 MB WRAM image buffer and 2 MB WRAM overlay buffer for non-destructive overlay
- image buffer can be panned and scrolled independently of the overlay plane

## Supports single, dual-screen, and dual-head modes

- can act as a main system display of user interface and live video display with text or graphics overlay, all on a single screen
- can capture and display live video with overlay on one monitor while an additional display board displays the desktop on a second monitor
- using two boards, one large virtual desktop can be created and displayed across two monitors under Windows® NT 4.0/2000/XP

### Matrox VIA: display functions

- formats the data to be written to the image display buffer
- tags for selecting specific pixels to write to memory (1-bit per pixel) allows display of non-rectangular video-in-a-window, multiple overlapping windows with live video, etc.
- generates start-of-transfer, end-of-transfer and line transfer interrupts towards the host

## Matrox Genesis-LC

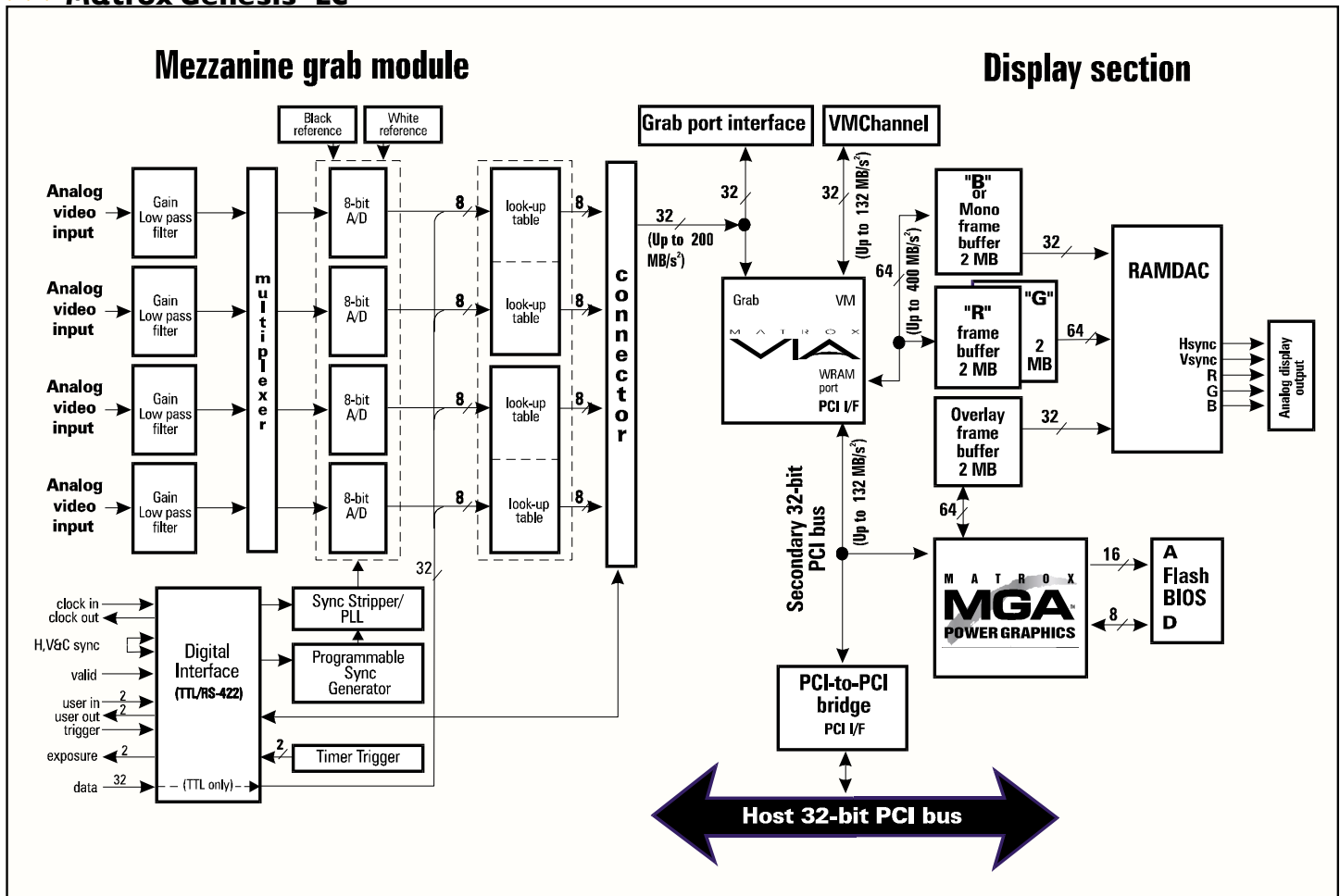

## Part of the Matrox Genesis Family

Matrox Genesis-LC is one of several configurations in the Matrox Genesis family. To satisfy applications that require dedicated onboard processing, the Matrox Genesis Main Board features a processing node with Texas Instruments' TMS320C80 DSP and Matrox neighborhood operations accelerator (NOA) ASIC and up to 64 MB onboard SDRAM. For scalable processing, add up to six Processor Boards with one or two nodes each.

## Software<sup>1</sup>

Software support is available for Microsoft® Windows® NT 4.0, Windows® 2000 and Windows® XP, and consists of Matrox Imaging Library (MIL)/ActiveMIL or MIL-Lite/ActiveMIL-Lite development toolkits for creating custom applications. Matrox Genesis-LC is also supported by Matrox Inspector Windows®-based interactive Imaging software.

## Hardware Specifications

### Acquisition

- monochrome or color, standard or non-standard, analog or digital
- frame scan or line scan
- up to 64K pixels per line and 64K lines

### analog

- 3 software-selectable modes
  - 4 channel/8-bit mode at up to 35 MHz
  - 2 channel/8-bit mode at up to 70 MHz
  - 1 channel/8-bit mode at up to 140 MHz
- 10 MHz low-pass filter (can be bypassed)
- PLL range: 5-35 MHz
- programmable clock phase: 0°, 90°, 180° and 270°
- programmable gain, offset and DC restoration

### digital

- supports 8, 16 and 32-bit words
- onboard up to 32-bit wide TTL input at up to 30 MHz
- optional digital input module provides up to 32-bit wide RS-422 at up to 25 MHz and LVDS at up to 40 MHz

### synchronization and control

- hsync, vsync, composite sync, pixel clock input or output (TTL/RS-422/LVDS)
- external trigger input (TTL/RS-422/LVDS)
- two exposure (timer) outputs (TTL/RS-422/LVDS)
- auxiliary I/Os (TTL/RS-422/LVDS): two in/two out

### configurable look-up tables

- four 256 x 8-bit or two 8k x 16-bit

## Data interface

- high-speed buses managed by Matrox VIA<sup>2</sup>:
  - 200 MB/s (32-bit/50MHz) grab port interface for acquiring high-rate video
  - 400 MB/s (64-bit/50MHz) local memory bus between display controllers (MGA/VIA) and memory (WRAM)
  - 132 MB/s (32-bit/33MHz) PCI bus for transferring data to system memory
  - 132 MB/s (32-bit/33MHz) VESA Media Channel (VMChannel™) for transferring images between boards (Matrox Genesis-LC used in conjunction with other Matrox Genesis-LC boards, Matrox Genesis Main Board or Processor Board)

## Display

- Matrox MGA 2064W graphics engine
- 6 MB WRAM image frame buffer
- 2 MB WRAM overlay frame buffer
- resolutions up to 1600 x 1200 @ 85 Hz refresh rate
- supports 1200 x 1600 portrait display mode
- non-destructive overlay of text and graphics

## Connector pinouts

- To see connector pinout diagrams for Matrox Genesis-LC, please visit the product section of the Matrox Imaging web site: [www.matrox.com/imaging/products/genesis-lc/](http://www.matrox.com/imaging/products/genesis-lc/)

## Dimensions and environmental information

### Matrox Genesis-LC

- 31.4 L x 10.7 H cm (12.4" x 4.2") H: bottom edge of goldfinger to top edge of board
- 34.1 L x 10.7 H cm (13.4" x 4.2") includes retainer
- operating temperature: 0° C to 55° C (32° F to 131° F)
- relative humidity: up to 95% (non-condensing)
- power consumption: 2.45A @ 5V or 12.25W; 230mA @ 12V or 2.76W; 145.4mA @ -12V or 1.75W

## Software Environment

- drivers for Windows® NT 4.0, Windows® 2000, Windows® XP and QNX®<sup>1</sup>
- programmed using DLL interface (MIL/MIL-Lite) with Microsoft® Visual C++®
- programmed using ActiveX (OCX) interface (ActiveMIL/ActiveMIL-Lite) with Microsoft® Visual Basic® or C++®
- QNX®<sup>1</sup> development done using LIB interface with QNX®/IDE

## Ordering Information

Part number	Description
<b>Hardware</b> GEN/X/00/8/STD or /LVDS	Standard/non-standard analog color/monochrome line/area scan PCI frame grabber with integrated 8 MB display.
GEN-DIG-BRD/X/Y	Digital input companion board. X is R for RS-422 and L for LVDS (requires/LVDS option). Y is P for PCI and I for ISA.
GEN-CBLADT/PCI	Digital cable adapter board for the PCI form factor.
Ordered separately:	
<b>Software</b> MIL LITE 7	MIL-Lite board control library (see MIL-Lite brochure for more details).
MIL 7 DEV P or U	Matrox Imaging Library (MIL) (see MIL brochure for more details).
INSPECTOR 4 P or U	Matrox Inspector (see Inspector brochure for more details).

## Analog input cables

IMG-7W2-TO-5BNC 2.4 m (8') input cable, one 7W2 to five BNCs.

## Digital input cables

DBHD100-TO-OPEN 3 m (10') cable, DBHD-100 to an open end (requires customization).

PLS/CBL/OPEN Input cable, high density DB-68 (SCSI-2 type) to an open end (for synch and control only).

Custom camera cables available for Matrox Genesis-LC. Contact Matrox Imaging Sales for more information.

## Notes:

1. QNX supported through Matrox Genesis Native Library (GNL)
2. Bus speeds given are maximum theoretical transfer speed.

# matrox

For more information, please call: 1-800-804-6243 (toll free in North America) or (514) 822-6020 or e-mail: [imaging.info@matrox.com](mailto:imaging.info@matrox.com) or <http://www.matrox.com/imaging>

### Corporate headquarters:

Canada and U.S.A.  
Matrox Electronic Systems Ltd.  
1055 St. Regis Blvd.  
Dorval, Quebec H9P 2T4  
Canada  
Tel: (514) 685-2630  
Fax: (514) 822-6273

### Offices:

Europe, Middle East & Africa  
Matrox VITE Limited  
Sefton Park  
Stoke Pages  
Buckinghamshire  
SL2 4JS  
U.K.  
Tel: 01753 665511  
Fax: 01753 665599

France  
Matrox France SARL  
2, rue de la Couture  
Silic 225  
94528 Rungis Cedex  
Tel: (0) 1 45-60-62-00  
Fax: (0) 1 45-60-62-05

Germany  
Matrox Electronic Systems GmbH  
Inselkammerstr. 8  
D-82008 Unterhaching  
Germany  
Tel: 089/62170-0  
Fax: 089/614 9743

All trademarks by their respective owners are hereby acknowledged. Matrox Electronic Systems, Ltd. reserves the right to make changes in specifications at any time and without notice. The information furnished by Matrox Electronic Systems, Ltd. is believed to be accurate and reliable. However, no responsibility license is granted under any patents or patent rights of Matrox Electronic Systems, Ltd. Windows and Microsoft are trademarks of Microsoft Corporation. MMX and the MMX logo are registered trademarks of Intel Corporation. Printed in Canada, 19-06-2002. **5IE-4918-B**